

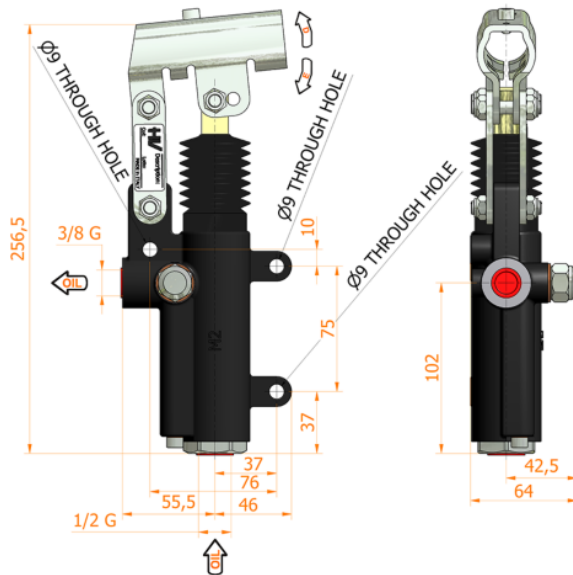

# PMP 20 byB-e-s

without release hand knob  
with pressure relief valve  
double acting hand pump for single acting cylinder  
for fixing to wall

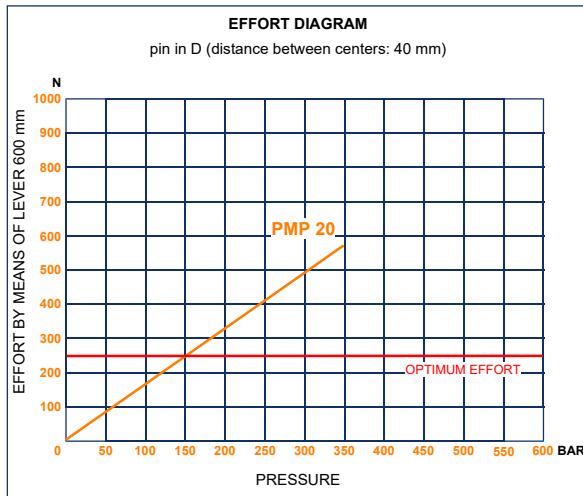
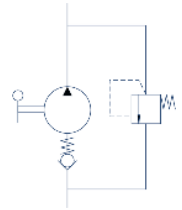

**Specifications:**

- Cast iron body
- Piston treated with Niploy
- White zinc plated support lever
- Lever connection Ø 27
- White zinc plated external parts
- Standard colour black
- Pressure relief valve standard setting: 100 bar

DISPLACEMENT cm <sup>3</sup>	A mm	B mm	C mm	D °	E °	ACTUAL DISPLACEMENT cm <sup>3</sup>	PRESSURE BAR		MASS KG	CODE WITHOUT BELLOWS	CODE WITH BELLOWS
							OPTIMAL	MAX			
20	--	--	--	32	30	20,090	150	350	2,650	6074.0058	6074.0063